

THE NEW VALUE FRONTIER



KC175GT

HIGH EFFICIENCY MULTICRYSTAL PHOTOVOLTAIC MODULE



LISTED

HIGHLIGHTS OF KYOCERA PHOTOVOLTAIC MODULES

Kyocera's advanced cell processing technology and automated production facilities produce a highly efficient multicrystal photovoltaic module.

The conversion efficiency of the Kyocera solar cell is over 16%. These cells are encapsulated between a tempered glass cover and a pottant with PVF back sheet to provide efficient protection from the severest environmental conditions.

The entire laminate is installed in an anodized aluminum frame to provide structural strength and ease of installation. Equipped with plug-in connectors.



APPLICATIONS

KC175GT is ideal for grid tie system applications.

- Residential roof top systems
- Large commercial grid tie systems
- Water Pumping systems
- High Voltage stand alone systems
- etc.

QUALIFICATIONS

- **MODULE** : UL1703 certified
- **FACTORY** : ISO9001 and ISO 14001

QUALITY ASSURANCE

Kyocera multicrystal photovoltaic modules have passed the following tests.

- Thermal cycling test
- Thermal shock test
- Thermal / Freezing and high humidity cycling test
- Electrical isolation test
- Hail impact test
- Mechanical, wind and twist loading test
- Salt mist test
- Light and water-exposure test
- Field exposure test

LIMITED WARRANTY

※ 1 year limited warranty on material and workmanship

※ 20 years limited warranty on power output: For detail, please refer to "category IV" in Warranty issued by Kyocera

(Long term output warranty shall warrant if PV Module(s) exhibits power output of less than 90% of the original minimum rated power specified at the time of sale within 10 years and less than 80% within 20 years after the date of sale to the Customer. The power output values shall be those measured under Kyocera's standard measurement conditions. Regarding the warranty conditions in detail, please refer to Warranty issued by Kyocera)

ELECTRICAL CHARACTERISTICS

Current-Voltage characteristics of Photovoltaic Module KC175GT at various cell temperatures

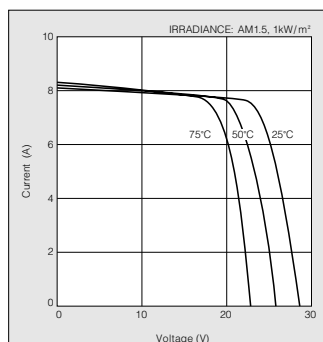

Current-Voltage characteristics of Photovoltaic Module KC175GT at various irradiance levels

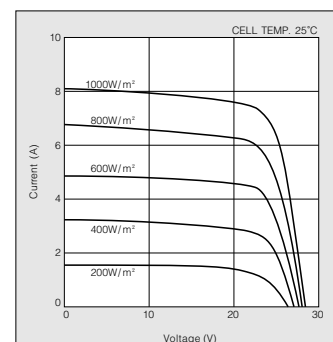

MODEL
KC175GT

☒ **Physical Specifications**

Unit : mm (in.)

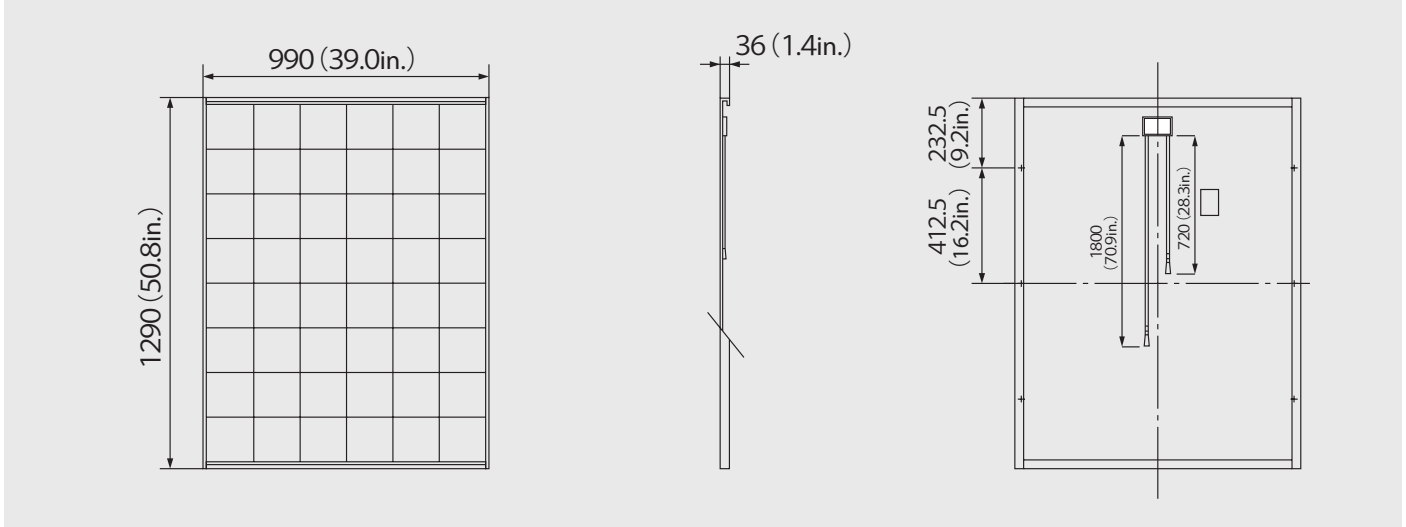

☒ **Specifications**

☒ Electrical Performance under Standard Test Conditions (*STC)	
Maximum Power (Pmax)	175W (+10%/−5%)
Maximum Power Voltage (Vmpp)	23.6V
Maximum Power Current (Impp)	7.42A
Open Circuit Voltage (Voc)	29.2V
Short Circuit Current (Isc)	8.09A
Max System Voltage	600V
Temperature Coefficient of Voc	−1.09 × 10 ⁻¹ V/°C
Temperature Coefficient of Isc	3.18 × 10 ⁻³ A/°C

*STC : Irradiance 1000W/m², AM1.5 spectrum, module temperature 25℃

☒ Electrical Performance at 800W/m ² , NOCT, AM1.5	
Maximum Power (Pmax)	125W
Maximum Power Voltage (Vmpp)	20.9V
Maximum Power Current (Impp)	5.99A
Open Circuit Voltage (Voc)	26.5V
Short Circuit Current (Isc)	6.53A

NOCT (Nominal Operating Cell Temperature) : 47℃

☒ Cells	
Number per Module	48

☒ Module Characteristics	
Length × Width × Depth	1290mm (50.8in.) × 990mm (39.0in.) × 36mm (1.4in)
Weight	16.0kg (35.3lbs.)
Cable	(+)720mm (28.3in.), (-)1800mm (70.9in)

☒ Junction Box Characteristics	
Length × Width × Depth	113.6mm (4.5in.) × 76mm (3.0in.) × 9mm (0.4in)
IP Code	IP65

☒ Reduction of Efficiency under Low Irradiance	
Reduction	5.1%

Reduction of efficiency from an irradiance of 1000W/m² to 200W/m² (module temperature 25℃)

Please contact our office for further information



KYOCERA Corporation

☒ **KYOCERA Corporation Headquarters**
 CORPORATE SOLAR ENERGY DIVISION
 6 Takeda Tobadono-cho
 Fushimi-ku, Kyoto
 612-8501, Japan
 TEL:(81)75-604-3476 FAX:(81)75-604-3475
<http://www.kyocera.com>

Distributor

Renewpowers Technologies Pte Ltd
 +65 6741 7123 Phone
 +65 6441 7379 Fax
rpt@renewpowers.com
www.renewpowers.com

