

Pyrgeometer



Pyrgometer MS-202 is designed to measure long-wave radiation beyond $3\mu\text{m}$. A specially coated silicon dome transmits incident radiation of wavelength greater than $3\mu\text{m}$ by cutting off the shorter wavelengths. The radiative compensation circuit with a thermistor is integrated into pyrgometer MS-202. This circuit is used for the sensor body temperature measurement. The infrared radiation is output as an analogue voltage, which is decided by compensating the incident radiation from the atmosphere or earth-ground with the radiation emitted from the heat of detector itself. The infrared radiation can be easily measured from only this analogue output.

A thermistor dome temperature sensor is available as an option.
Pt-100 temperature sensor for both the sensor body temperature and the dome temperature is also available as an option.

Specifications

Spectral range	4 to 50 μm
Response time	approx. 3 sec. (1-1/e)
Non-linearity	$\pm 1\%$
Sensitivity	approx. 4mV/kWm^{-2}
Internal resistance	approx. 300Ω
Weight	2kg (MS-202), 3kg (MS-202F)
Power requirement	Temperature-compensation circuit Lithium battery 3V, CR123 Battery life 7months Blower fan (MS-202F) AC100, 110, 220V (50/60Hz) DC12,24V

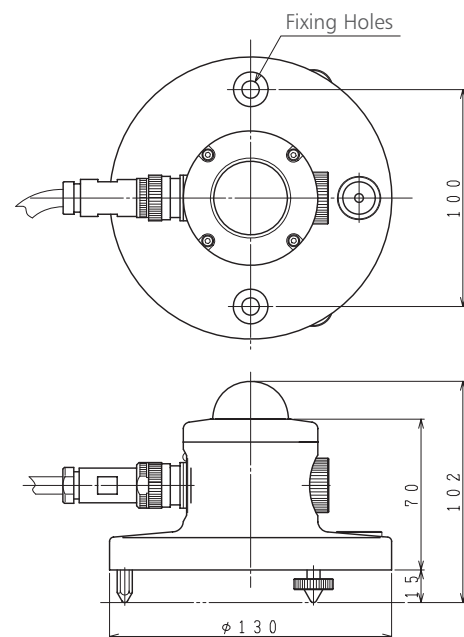

Selections of temperature sensors

Thermistor (body) with the compensating circuit

Following options are available:

- 1). Thermistor (body) with the circuit and additional Thermistor (dome)
- 2). Pt100 (body, 4 wire) output
- 3). 2 Pt100 (body and dome, 4-wire) outputs
- 4). Blower fan (model MS-202F)