

Sunshine Duration Meter

EKO Sunshine Duration Meter MS-093 has a specially designed and rotating mirror, which reflects the direct solar radiation onto a spectrally flat pyroelectric sensor. This sensor outputs a differential coefficient as voltage, which is proportional to the direct solar irradiance.

MS-093 measure only the direct solar radiation without being affected by the diffuse radiation due to the above mentioned unique method.

WMO define the sunshine duration as the amount of time when the direct solar irradiance exceeds $120\text{W} \cdot \text{m}^{-2}$.

MS-093 measure the direct solar irradiance exceeds the threshold value $120\text{W} \cdot \text{m}^{-2}$. Therefore, reliable sunshine duration data can be obtained.

Internal CPU processes the signals sent by the sensor, then outputs a pulse as sunshine duration when the direct solar irradiance exceeds the threshold value.

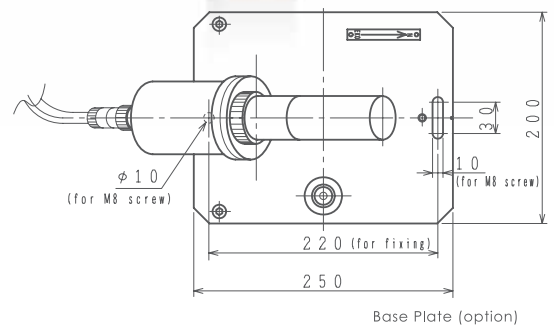

Base Plate (option)

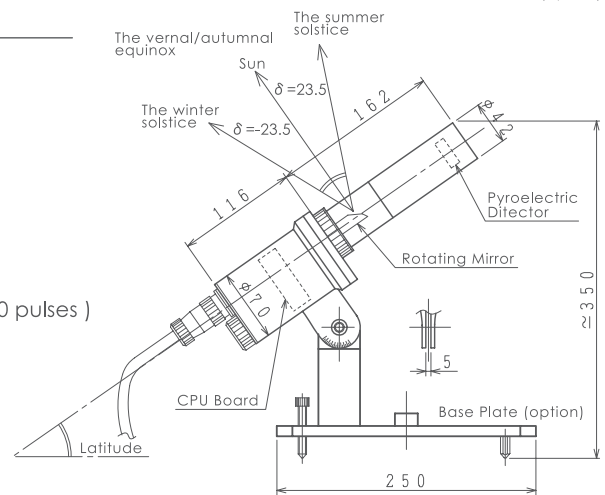

Specifications

Measurement method	: Rotating mirror
Detector	: Pyroelectric sensor
Mirror rotation / hour	: 100 rph (option:120 rph)
Threshold value	: $120\text{W}/\text{m}^2$ of direct solar irradiance
Spectral response	: 0.3 to $2.5\mu\text{m}$
Declination error	: $\pm 5\%$
Non-linearity	: $\pm 2.5\%$ (Direct solar irradiance)
Temperature response	: $\pm 5\%$ (-20 to 40°C)
Sunshine duration	: 100 pulses/h under clear sky (option 120 pulses)
Integration error	: Less than 10 min/day
Operating temperature range	: -20 to $+40^\circ\text{C}$
Power requirements	: AC100~240V, 0.3A, 50/60Hz
Weight	: 3.2 kg