

Smart choice for power

xantrex

The CR Inverter/Charger creates dependable electricity for a very low price!



Affordable backup power solution

The entry-level CR Series provides AC power without interruption to keep your critical equipment running during a power outage. Built with an automatic transfer switch, the CR instantly switches to battery power during a blackout or brownout. When AC power is restored it automatically recharges the battery.

Available in 1000, 1500 and 2400 watt models, it is ideal for powering common loads such as refrigerators, computers, lights, small televisions, radios and fans.

Features

- ▶ Automatic, fast transfer ensures no intermittent loss of power to your critical loads
- ▶ Built-in battery charging ensures batteries are fully charged and ready to use while protecting them from being overcharged
- ▶ Low and high battery voltage and overload protection circuitry
- ▶ Audible alarms to indicate low battery voltage, overload, and fault conditions
- ▶ Front panel LED indicators to provide status-at-a-glance

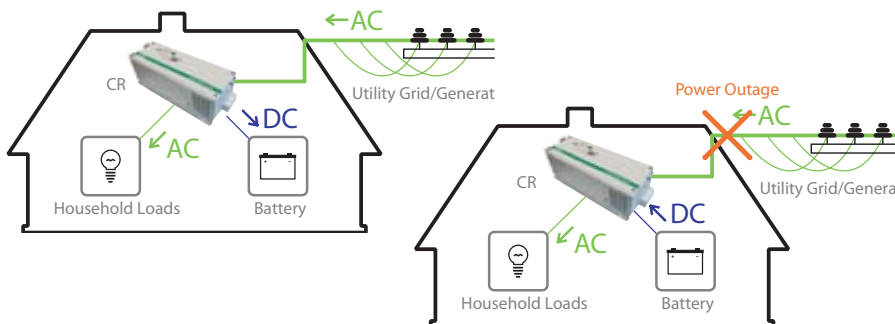

The CR Series combines the key benefits of uninterruptible power supplies with the runtime allowed by a larger battery bank. Backup power time is flexible – you can connect as many batteries as you need.

120VAC, 60Hz & 230VAC, 50Hz
Entry Level Inverter/Charger

Xantrex Technology Inc.

Headquarters
8999 Nelson Way
Burnaby, British Columbia
Canada V5A 4B5
800 670 0707 Toll Free
604 420 1591 Fax

Distributor

Renewpowers Technologies Pte Ltd

+65 8183 9088 Phone
+65 6441 7379 Fax
rpt@renewpowers.com
www.renewpowers.com



CR Series Inverter/Charger

Electrical Specifications			
Models	CR1012 (12Vdc, 120Vac/60Hz)	CR1512 (12Vdc, 120Vac/60Hz)	CR2412 (12Vdc, 120Vac/60Hz)
	CR1012E (12Vdc, 230Vac/50Hz)	CR1512E (12Vdc, 230Vac/50Hz)	CR2412E (12Vdc, 230Vac/50Hz)
	CR1024 (24Vdc, 120Vac/60Hz)	CR1524 (24Vdc, 120Vac/60Hz)	CR2424 (24Vdc, 120Vac/60Hz)
	CR1024E (24Vdc, 230Vac/50Hz)	CR1524E (24Vdc, 230Vac/50Hz)	CR2424E (24Vdc, 230Vac/50Hz)

Invert Mode Specifications				
Continuous Output Power		1000W	1500W	2400W
Surge Capability		1500W	2250W	3600W
Output Voltage		120 VAC / 230 VAC	120 VAC / 230 VAC	120 VAC / 230 VAC
Output Frequency		50 Hz / 60 Hz \pm 0.3 Hz	50 Hz / 60 Hz \pm 0.3 Hz	50 Hz / 60 Hz \pm 0.3 Hz
Output Waveform		Modified Sinewave	Modified Sinewave	Modified Sinewave
Peak Efficiency (DC to AC)		86%	86%	86%
DC Input Voltage		12 V or 24 V	12 V or 24 V	12 V or 24 V
DC Input Voltage Range	12V battery	10.5V - 14.5V	10.5V - 14.5V	10.5V - 14.5V
	24V battery	21V - 29V	21V - 29V	21V - 29V
DC Current at Rated Power	12V battery	101A	152A	247A
	24V battery	50A	74A	122A
Low Battery Warning	12V battery	11V \pm 0.2V	11V \pm 0.2V	11V \pm 0.2V
	24V battery	22V \pm 0.2V	22V \pm 0.2V	22V \pm 0.2V
Low Battery Shutdown	12V battery	10.5V \pm 0.2V	10.5V \pm 0.2V	10.5V \pm 0.2V
	24V battery	21V \pm 0.2V	21V \pm 0.2V	21V \pm 0.2V

Charger/Bypass Mode Specifications				
AC Input Voltage Range		85 VAC-132 VAC / 184 VAC-253 VAC \pm 4%	85 VAC-132 VAC / 184 VAC-253 VAC \pm 4%	85 VAC-132 VAC / 184 VAC-253 VAC \pm 4%
Reconnect Voltage Range		95 VAC-127 VAC / 194 VAC-243 VAC	95 VAC-127 VAC / 194 VAC-243 VAC	95 VAC-127 VAC / 194 VAC-243 VAC
AC Input Frequency Range		47 Hz-53 Hz / 57 Hz-63 Hz \pm 0.3 Hz	47 Hz-53 Hz / 57 Hz-63 Hz \pm 0.3 Hz	47 Hz-53 Hz / 57 Hz-63 Hz \pm 0.3 Hz
Max Total AC Input Current	120 VAC	14.0 Arms	18.1 Arms	27.0 Arms
	(Charge + Bypass) 230 VAC	7.4 Arms	9.4 Arms	14.1 Arms
Rated AC Bypass Current	120 VAC	8.3 Arms	12.5 Arms	20.0 Arms
	230 VAC	4.4 Arms	6.5 Arms	10.4 Arms
Relay Transfer Time		20 ms (typical)	20 ms (typical)	20 ms (typical)
Charging Voltage	12V battery	13.5 VDC	13.5 VDC	13.5 VDC
	24V battery	27.0 VDC	27.0 VDC	27.0 VDC
Max Charging Current	12V battery	40A	40A	50A
	24V battery	20A	20A	25A

General Specifications				
Operating Temperature Range		0°C to 40°C (32°F to 104°F)	0°C to 40°C (32°F to 104°F)	0°C to 40°C (32°F to 104°F)
Enclosure Type		Indoor, ventilated, steel chassis with powdercoat finish		
Unit Weight		40 lb (18kg)	44 lb (20kg)	61 lb (27.5 kg)
Inverter Dimensions		22.8 x 8.9 x 7" (579mm x 227mm x 179mm)		
Shipping Dimensions		26.75 x 12.5 x 12" (680 mm x 318 mm x 305 mm)		
Warranty		1 year		

Specifications subject to change without notice.